

Vertical Bearings Series V For Slow and Medium Speed Machines

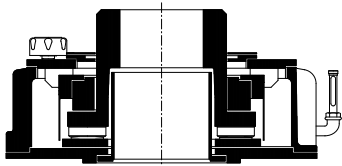

Type VT



Type VG

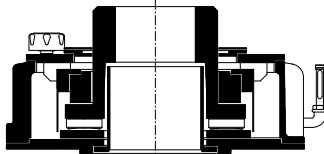

RENK vertical bearings, series V, are mainly used with slow to medium speed vertical machines (e. g. pumps, fans, turbines or electrical machines).

Many years of experience in the manufacture of vertical bearings, plus the latest methods of computing bearing performance, together with systematic design improvements, have culminated in the highly successful range of V-bearings.

V-bearings are supplied for thrust loads ranging to 965 kN. The corresponding shaft diameters are from 70 to 425 mm.

For high speed machines we have developed the series EV. Please consult our brochure RH-1021 for further information.

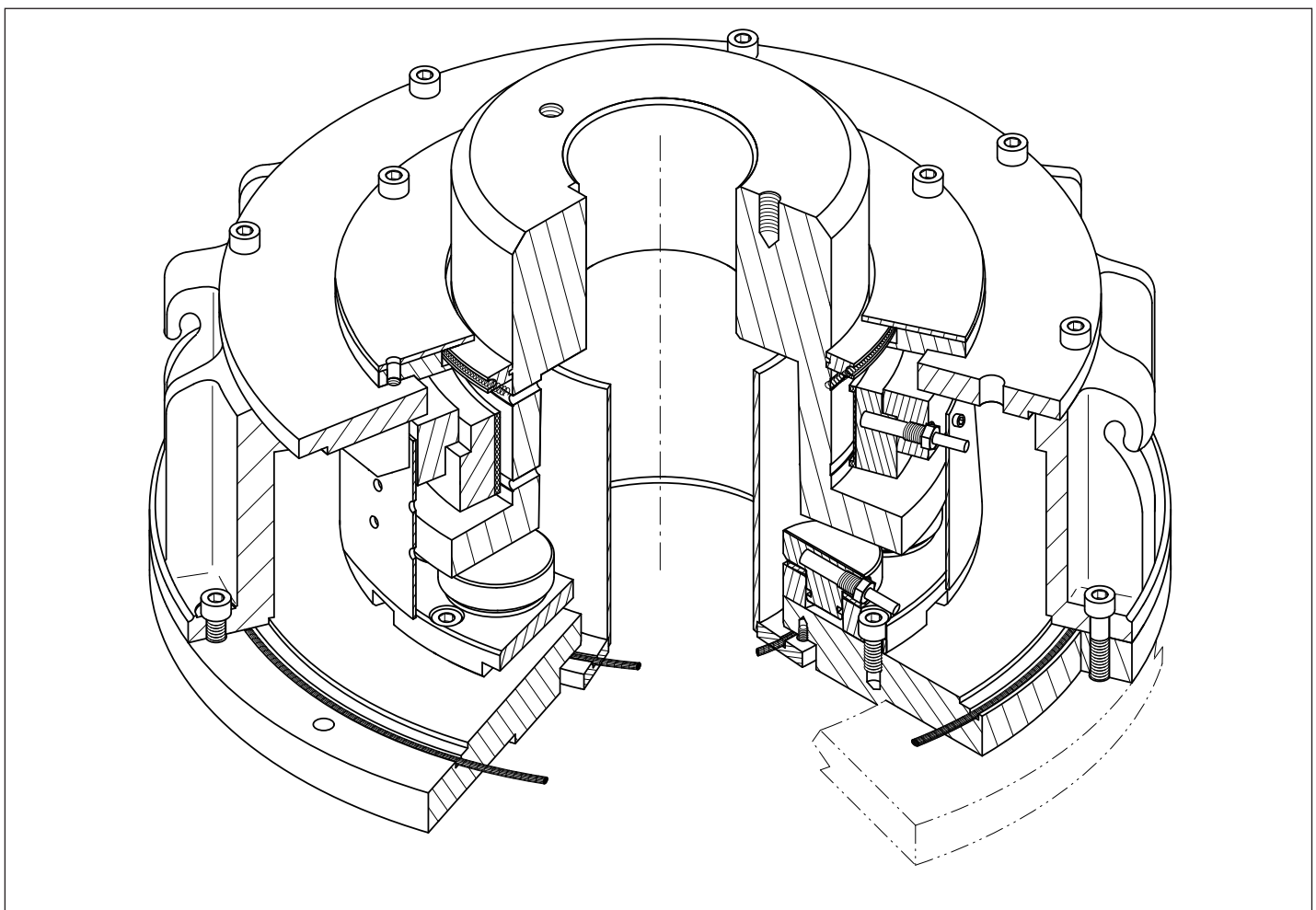

Technical Information

VT-bearings are designed as combined thrust and guide bearings with axial and journal parts; whereas the VG bearings are supplied as guide bearings with journal part only.

The bearing housing is designed in accordance with FEM to absorb high axial loads, including shock loads.

The journal and axial inserts can be used in combination with housings of different sizes.

In the case of slow speed machines the heat dissipation will be natural cooling. In such cases, a relatively small bearing housing will be necessary, since the oil quantity is low and there is no need for space for a water cooler. The same applies to medium speed bearings connected to an external oil system.

Due to the higher oil quantity, the medium speed bearings need a larger housing.

RENK can offer you the most suitable bearing housing to satisfy each specific application.

The bearing housing, made of 3 separate parts (bottom, jacket, cover), is easy to service. Removal or installation of the journal or axial parts is also easy.

Axial Part

The circular, tilting RD-thrust pads are a major characteristic of the VT bearings. The pads are supported on cup springs which ensure uniform load distribution. The bearings as standard are provided with 12 RD-thrust pads which support downward loads. If required, the bearing shell can be provided with a variable number of RS-thrust pads to take upward axial loads.

Journal Part

The journal part functions as a guide bearing. The plain cylindrical bore is provided with several lubricating grooves. If

required, the bearing can be provided with a four lobe shell instead of the plain cylindrical bore. This type of shell has a stabilising effect when the shaft is not loaded or only slightly loaded.

Heat Dissipation and Lubrication

Depending on the application and operating conditions the VT- and VG-bearings are used with

- natural cooling
- natural cooling with fan,
- cooling by external oil circulation,
- water cooling
- or
- water cooling plus fan cooling.

In the case of a water-cooled bearing the cooler is mounted into the bearing housing. Depending on the water quality, the cooler is made of Cu or CuNi10Fe or titanium (finned tube cooler).

The use of a fan makes the application of a natural cooled bearing with higher speeds possible.

If a circulating oil system is used, the housing is provided with an overflow weir. The weir maintains a bath of oil within the bearing housing to ensure safe short-term lubrication in the event of an external oil supply failure.

Temperature Monitoring

For temperature monitoring of the thrust pads or of the guide bearing RENK supplies the especially developed resistance thermometer sensors (PT 100).

Oil Flow Control for Circulating Oil Systems

We recommend the use of the flow meter type NJV-MI, especially developed for application with slide bearings. These flow meters can be checked visually or, if fitted with a switching device, can be monitored electrically.

① Series	V vertical bearing										
② Type	<table border="0"> <tr><td>T</td><td>thrust and guide</td></tr> <tr><td>G</td><td>guide only</td></tr> <tr><td>B</td><td>thrust and guide with upward thrust face</td></tr> <tr><td>X</td><td>special design</td></tr> </table>	T	thrust and guide	G	guide only	B	thrust and guide with upward thrust face	X	special design		
T	thrust and guide										
G	guide only										
B	thrust and guide with upward thrust face										
X	special design										
③ Heat dissipation and lubrication	<table border="0"> <tr><td>N</td><td>natural cooling</td></tr> <tr><td>Z</td><td>lubrication by oil circulation with external oil cooling</td></tr> <tr><td>W</td><td>water cooling (finned tubes in oil sump)</td></tr> <tr><td>F</td><td>fan cooling</td></tr> <tr><td>X</td><td>special cooling systems</td></tr> </table>	N	natural cooling	Z	lubrication by oil circulation with external oil cooling	W	water cooling (finned tubes in oil sump)	F	fan cooling	X	special cooling systems
N	natural cooling										
Z	lubrication by oil circulation with external oil cooling										
W	water cooling (finned tubes in oil sump)										
F	fan cooling										
X	special cooling systems										
④ Shape of bore	<table border="0"> <tr><td>C</td><td>plain cylindrical bore</td></tr> <tr><td>V</td><td>four-lobe bore</td></tr> </table>	C	plain cylindrical bore	V	four-lobe bore						
C	plain cylindrical bore										
V	four-lobe bore										
⑤ Bearing cover	<table border="0"> <tr><td>U</td><td>non-split</td></tr> <tr><td>G</td><td>split</td></tr> </table>	U	non-split	G	split						
U	non-split										
G	split										
⑥ Bearing size											
⑦ Housing size											

Example

for bearing coding

① ② ③ ④ ⑤ ⑥ ⑦
V T N C U 11 - 5

- ① vertical bearing type V
- ② thrust and guide bearing
- ③ heat dissipation by natural cooling
- ④ cylindrical bore
- ⑤ bearing cover non-split
- ⑥ bearing size 11
- ⑦ housing size 5



Dimensions of the Bearing Type VTNCU

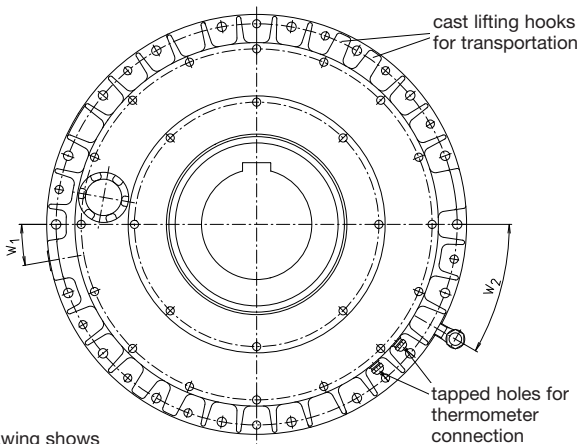
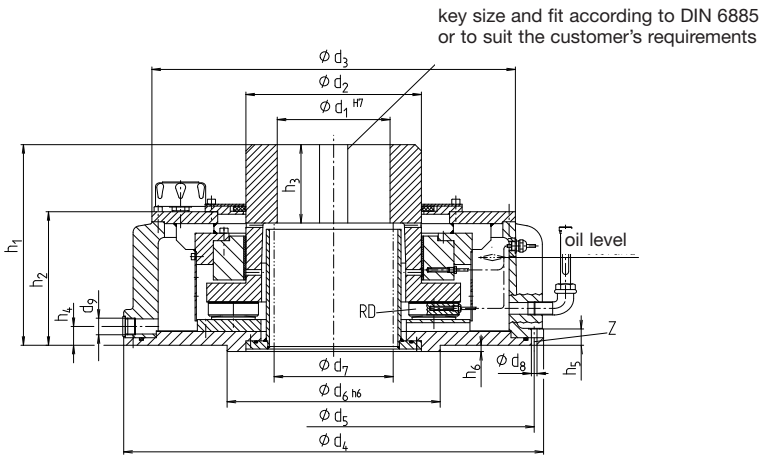

drawing shows type VTNCU 18-16

Bearing size	RD [12 x]	F _{Rmin} [kN]	F _{Rmax} [kN]	F _{AS} [kN]	F _{AB} [kN]
7	31,5	0,3	6	23	28
9	40	0,4	7,5	37	60
11	50	0,6	12	58	94
14	63	1,0	20	93	149
16	71	1,3	25	118	190
18	80	1,6	31	150	241
20	90	2,0	39	190	305
22	100	3,0	53	235	377
25	112	3,5	68	295	472
28	125	4,5	85	368	589
31	140	5,5	106	461	738
40	160	7,0	138	603	965

Final selection of bearing according to the EDP-calculations
start load with closed valve upon request

F_{Rmin} = minimum radial load (shell with plain cylindrical bore)
F_{Rmax} = maximum radial load
F_{AS} = axial start up load
F_{AB} = axial operational load

Dimensions in mm

Size VTN	d ₁ max	d ₂	d ₃	d ₄	d ₅	d ₆	d ₇ max	d ₈	d ₉	h ₁	h ₂	h ₃	h ₄	h ₅	h ₆	z	w ₁ [°]	w ₂ [°]	Weight [kg] ¹⁾	Oil quantity [l]
7-5	70	125	370	440	410	250	75	9	G 3/4	197	150	70	30	22	10	12	15	45	85	6
9-5	90	140	370	440	410	250	93	9	G 3/4	200	150	75	30	22	10	12	15	45	90	5
11-5	110	180	370	440	410	250	115	9	G 3/4	220	155	80	30	22	10	12	15	45	105	4
11-10	110	180	460	540	510	250	115	9	G 3/4	220	177	80	30	25	10	12	15	45	145	8,5
14-10	140	225	460	540	510	280	150	9	G 3/4	265	180	100	30	25	10	12	15	45	185	8
14-16	140	225	580	670	640	280	150	9	G 3/4	265	210	100	30	25	10	18	10	30	250	17
16-16	160	250	580	670	640	320	170	9	G 3/4	300	210	115	30	25	10	18	10	30	270	18
16-28	160	250	690	790	760	320	170	11	G 3/4	300	242	115	30	25	10	18	10	30	335	29
18-16	180	280	580	670	640	340	190	9	G 3/4	320	210	125	30	25	10	18	10	30	345	22
18-28	180	280	690	790	760	340	190	11	G 3/4	320	242	125	30	25	10	18	10	30	410	29
18-40	180	280	810	920	880	340	190	11	G 3/4	320	270	125	34	28	10	20	9	27	510	45
20-28	200	315	690	790	760	380	220	11	G 1	355	250	140	35	30	10	18	10	30	415	24
20-40	200	315	810	920	880	380	220	11	G 3/4	355	280	140	40	35	10	20	9	27	510	42
22-28	220	375	690	790	760	420	235	11	G 1	400	255	160	37	32	10	18	10	30	520	22
22-40	220	375	810	920	880	420	235	11	G 3/4	400	285	160	40	35	10	20	9	27	630	41
22-55	220	375	910	1030	980	420	235	13,5	G 1	400	325	160	40	37	10	20	9	27	770	57
25-40	250	425	810	920	880	460	260	11	G 1	435	285	170	40	35	10	20	9	27	765	40
25-55	250	425	910	1030	980	460	260	13,5	G 1	435	325	170	41	38	10	20	9	27	880	60
28-55	280	475	910	1030	980	500	310	13,5	G 1	480	325	200	41	38	10	20	9	27	1030	53
28-78	280	475	1020	1150	1100	500	310	13,5	G 1	480	345	200	41	38	10	24	7,5	22,5	1160	78
31-55	320	530	910	1030	980	580	345	13,5	G 1	555	333	225	43	40	10	20	9	27	1243	41
31-78	320	530	1020	1150	1100	580	345	13,5	G 1	555	350	225	43	40	10	24	7,5	22,5	1410	77
40-100	400	600	1140	1280	1220	660	410	17,5	G 1	625	390	250	46	42	10	24	7,5	22,5	1870	100

¹⁾ without lubricant filling

Dimensions of the Bearing Type VTWCU

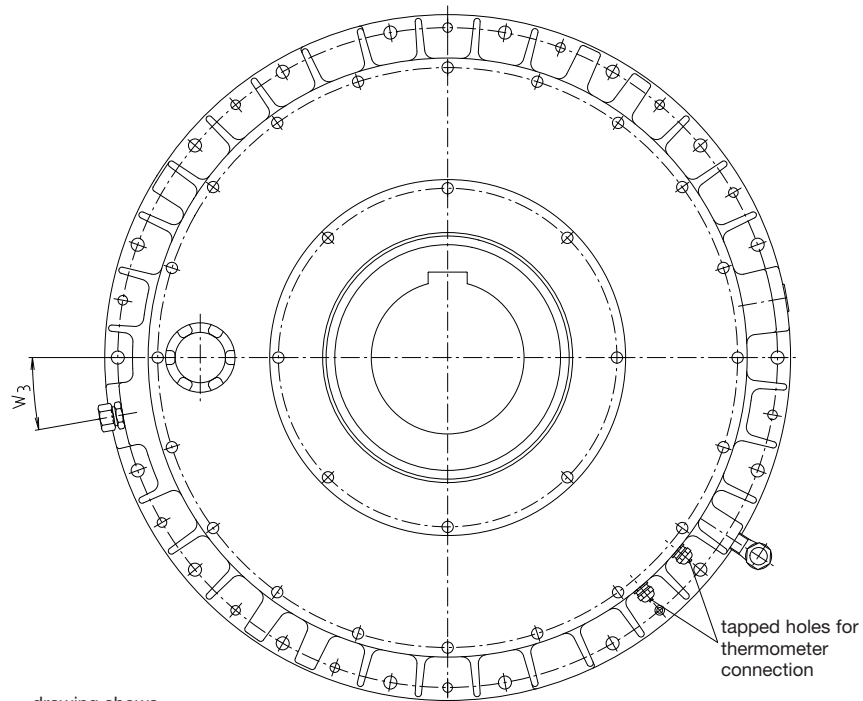
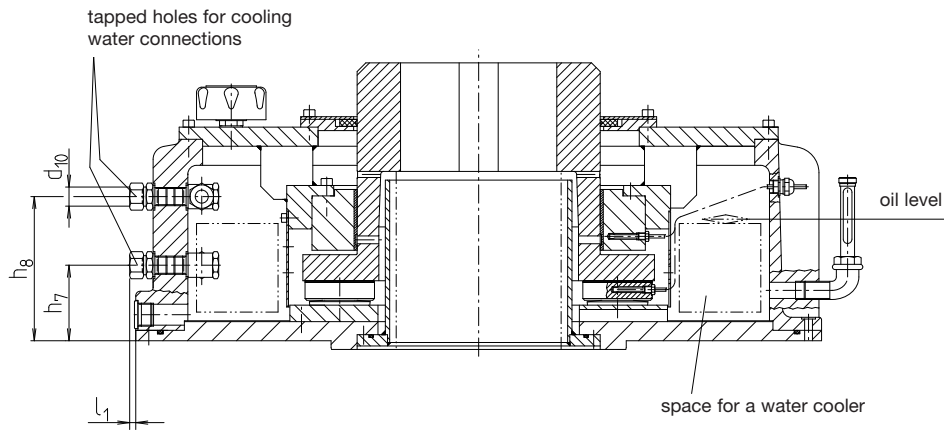

drawing shows type VTWCU 18-28

Dimensions in mm (for further dimensions please see page 3)

Size VTW	d ₁₀	h ₇	h ₈	l ₁	w ₃ [°]	Weight [kg] ¹⁾	Oil quantity [l]
7-5	12	40	90	2	15	87	6
9-5	15	40	90	3	15	95	5
11-5	15	40	90	3	15	110	4
11-10	15	50	110	10	15	150	8
14-10	15	50	110	10	15	190	7
14-16	15	60	130	10	10	260	15
16-16	15	60	130	10	10	280	16
16-28	15	70	160	8	10	345	26
18-16	15	60	130	10	10	350	21
18-28	15	70	160	8	10	420	26
18-40	15	70	180	8	9	525	39

Size VTW	d ₁₀	h ₇	h ₈	l ₁	w ₃ [°]	Weight [kg] ¹⁾	Oil quantity [l]
20-28	12	75	165	8	10	425	21
20-40	15	77	167	8	9	520	37
22-28	15	77	167	8	10	530	19
22-40	15	77	177	8	9	645	36
22-55	15	90	200	0	9	790	50
25-40	15	77	177	8	9	790	37
25-55	15	91	201	0	9	900	55
28-55	15	91	201	0	9	1050	45
28-78	22	90	206	-3	7,5	1190	65
31-55	15	93	203	0	9	1220	35
31-78	22	92	208	-3	7,5	1430	68
40-100	22	110	250	-5	7,5	1900	90

¹⁾ without lubricant filling



Dimensions of the Bearing Type VTZCU

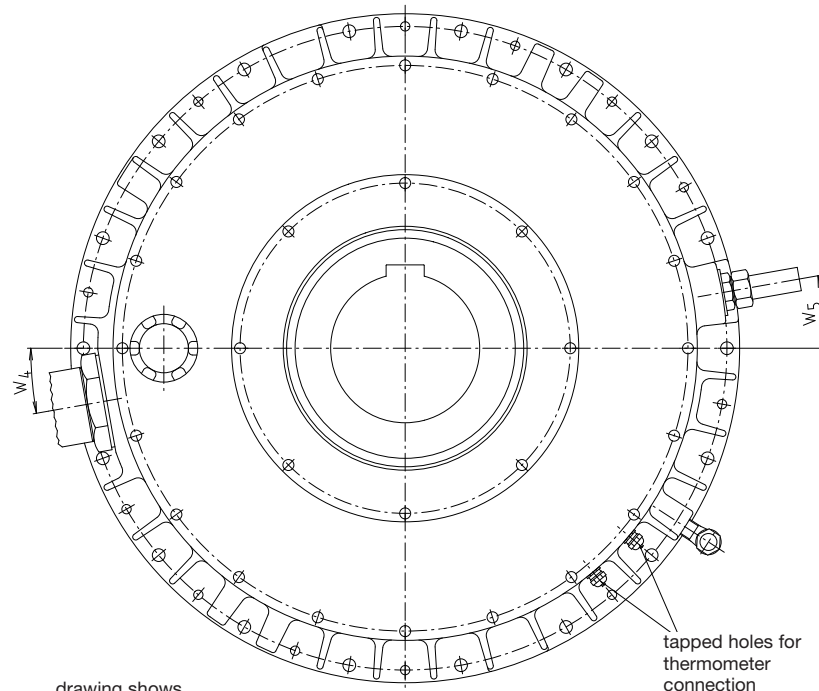
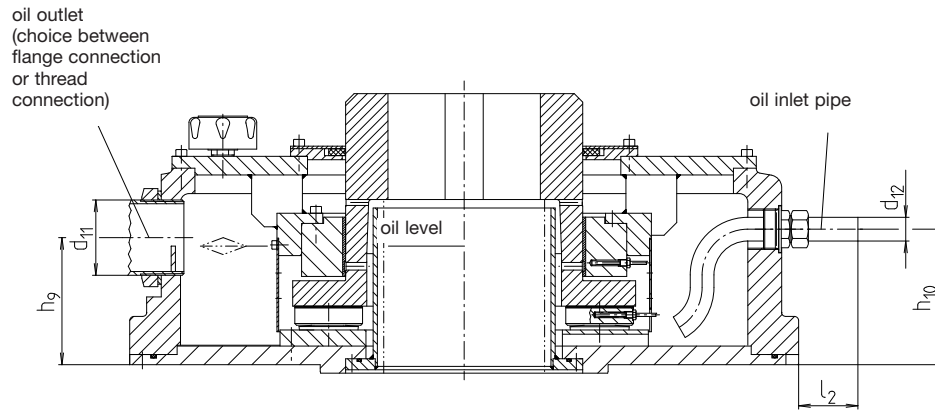

drawing shows
type VTZCU 18-28

Dimensions in mm (for further dimensions please see page 3)

Size VTZ	$d_{11}^{2)}$	d_{12}	h_9	h_{10}	l_2	w_4 [°]	w_5 [°]	Weight [kg] ¹⁾	Oil quantity [l]
7-5	G 1	10	95	103	50	15	15	85	6
9-5	G 1	12	95	103	50	15	15	90	5
11-5	G 1 1/2	18	95	103	50	15	15	105	4
11-10	G 1 1/2	18	105	120	50	15	15	145	8,5
14-10	G 2	22	105	117	50	15	15	185	8
14-16	G 2	22	125	140	50	10	10	250	17
16-16	G 2 1/2	22	130	140	50	10	10	270	18
16-28	G 2 1/2	22	145	160	50	10	10	335	29
18-16	G 2 1/2	28	128	143	60	10	10	345	22
18-28	G 2 1/2	28	150	165	60	10	10	410	29
18-40	G 2 1/2	28	140	160	60	9	9	510	45

Size VTZ	$d_{11}^{2)}$	d_{12}	h_9	h_{10}	l_2	w_4 [°]	w_5 [°]	Weight [kg] ¹⁾	Oil quantity [l]
20-28	G 3	35	150	170	70	10	10	415	24
20-40	G 3	35	165	185	70	9	9	510	42
22-28	G 4	38	150	170	70	10	10	520	22
22-40	G 4	38	160	180	70	9	9	630	41
22-55	G 4	38	180	200	70	9	9	770	57
25-40	G 3	38	180	200	70	9	9	765	40
25-55	G 3	38	185	205	70	9	9	880	60
28-55	G 4	38	190	210	70	9	9	1030	53
28-78	G 4	38	190	210	70	7,5	7,5	1160	78
31-55	G 4	38	205	225	70	9	9	1243	41
31-78	G 4	38	205	225	70	7,5	7,5	1420	77
40-100	G 4	38	235	255	70	7,5	7,5	1870	100

1) without lubricant filling

2) flange connection upon request

Dimensions of the Bearing Type VGNCU

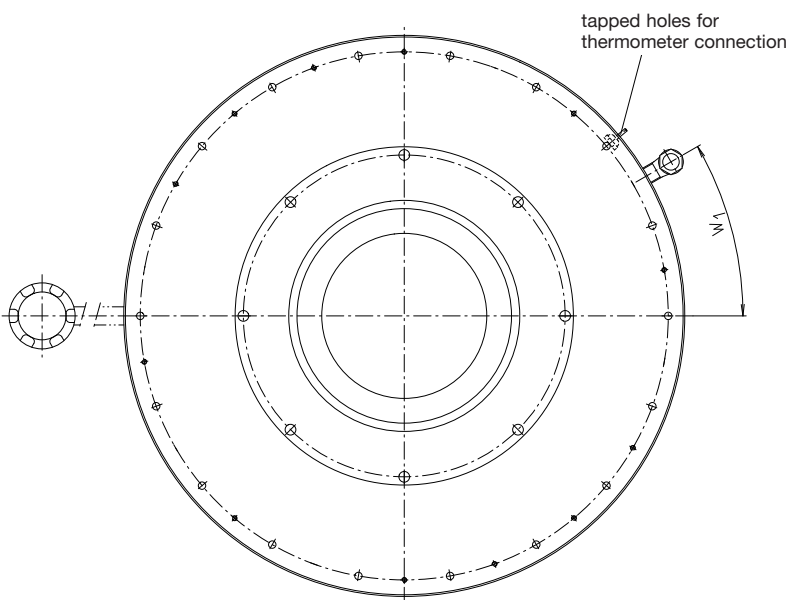
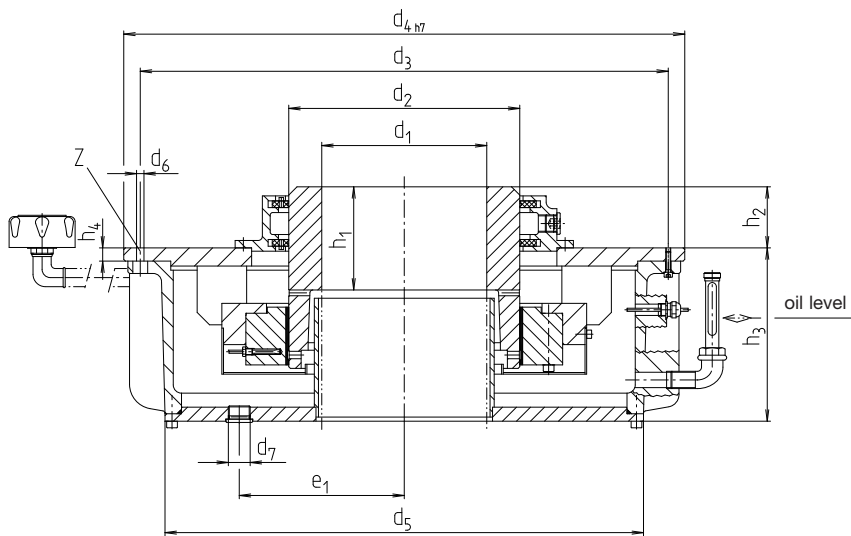

drawing shows type VGNCU 18-16

Bearing size	F_{Rmin} [kN]	F_{Rmax} [kN]
7	0,3	6
9	0,4	7,5
11	0,6	12
14	1,0	20
16	1,3	25
18	1,6	31
20	2,0	39
22	3,0	53
25	3,5	68
28	4,5	85
31	5,5	106
40	7,0	138

Final selection according to the EDP-calculation

F_{Rmin} = minimum radial load
(shell with plain cylindrical bore)
 F_{Rmax} = maximum radial load

Dimensions in mm

Size VGN	d_{1max}	d_2	d_3	d_4	d_5	d_6	d_7	h_1	h_2	h_3	h_4	e_1	z	w_1 [°]	Weight [kg] ¹⁾	Oil quantity [l]
7-5	80	125	410	450	370	9	G 3/4	65	45	148	12	140	12	75	62	7
9-5	90	140	410	450	370	9	G 3/4	70	50	148	12	140	12	75	65	8
11-5	125	180	410	450	370	9	G 3/4	80	50	148	12	140	12	75	75	4
14-10	160	225	510	550	460	9	G 3/4	100	60	178	14	200	12	75	130	7
16-16	180	250	640	680	580	9	G 3/4	115	60	210	16	240	18	50	200	16
18-16	200	280	640	680	580	9	G 3/4	125	75	210	16	240	18	50	230	14
20-28	225	315	760	800	690	11	G 1	140	80	250	20	290	18	52,5	305	29
22-28	250	375	760	800	690	11	G 1	160	120	250	20	290	18	52,5	345	33
25-40	315	425	880	930	810	11	G 1	170	120	280	23	320	20	47,5	515	43
28-55	335	475	980	1050	910	13,5	G 1	200	135	320	23	370	20	47,5	725	66
31-55	375	530	980	1050	910	13,5	G 1	225	205	320	23	370	20	47,5	895	69
40-78	425	600	1100	1160	1020	13,5	G 1	250	235	340	25	420	24	54,5	1185	97

1) without lubricant filling



Dimensions of the Bearing Type VGWCU

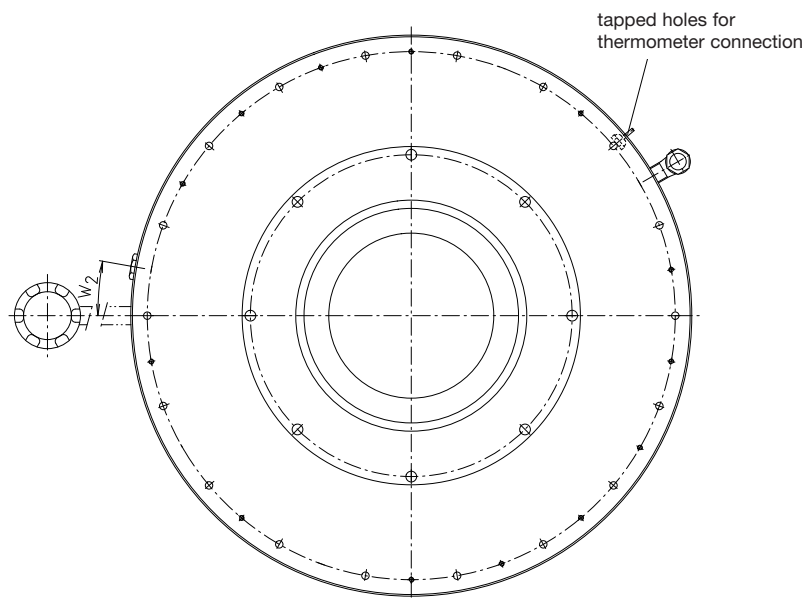
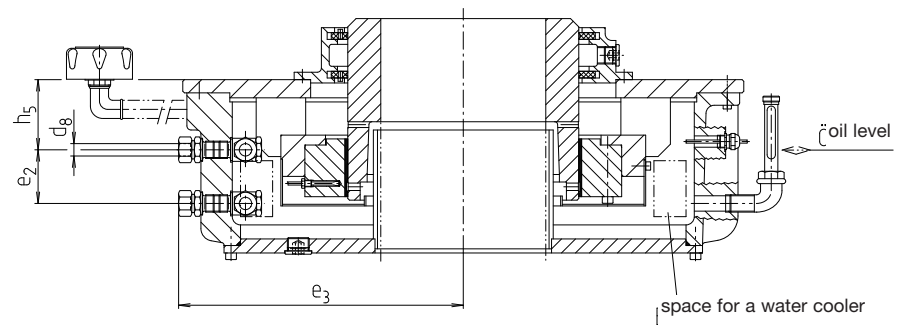

drawing shows type VGWCU 18-16

Dimensions in mm (for further dimensions see page 6)

Size VGW	d_8	h_5	e_2	e_3	w_2 [°]	Weight [kg] ¹⁾	Oil quantity [l]
7-5	15	50	50	472	15	63	6
9-5	15	50	50	472	15	66	8
11-5	15	50	50	472	15	76	4
14-10	15	60	65	560	15	135	7
16-16	15	90	60	588	10	205	15
18-16	15	90	60	588	10	235	13

Size VGW	d_8	h_5	e_2	e_3	w_2 [°]	Weight [kg] ¹⁾	Oil quantity [l]
20-28	15	100	80	692	10	310	28
22-28	15	100	80	692	10	350	32
25-40	15	120	90	812	9	520	42
28-55	15	130	100	514	9	730	65
31-55	15	120	100	514	9	900	69
40-78	15	140	120	569	7,5	1190	96

1) without lubricant filling

Dimensions of the Bearing Type VGZCU

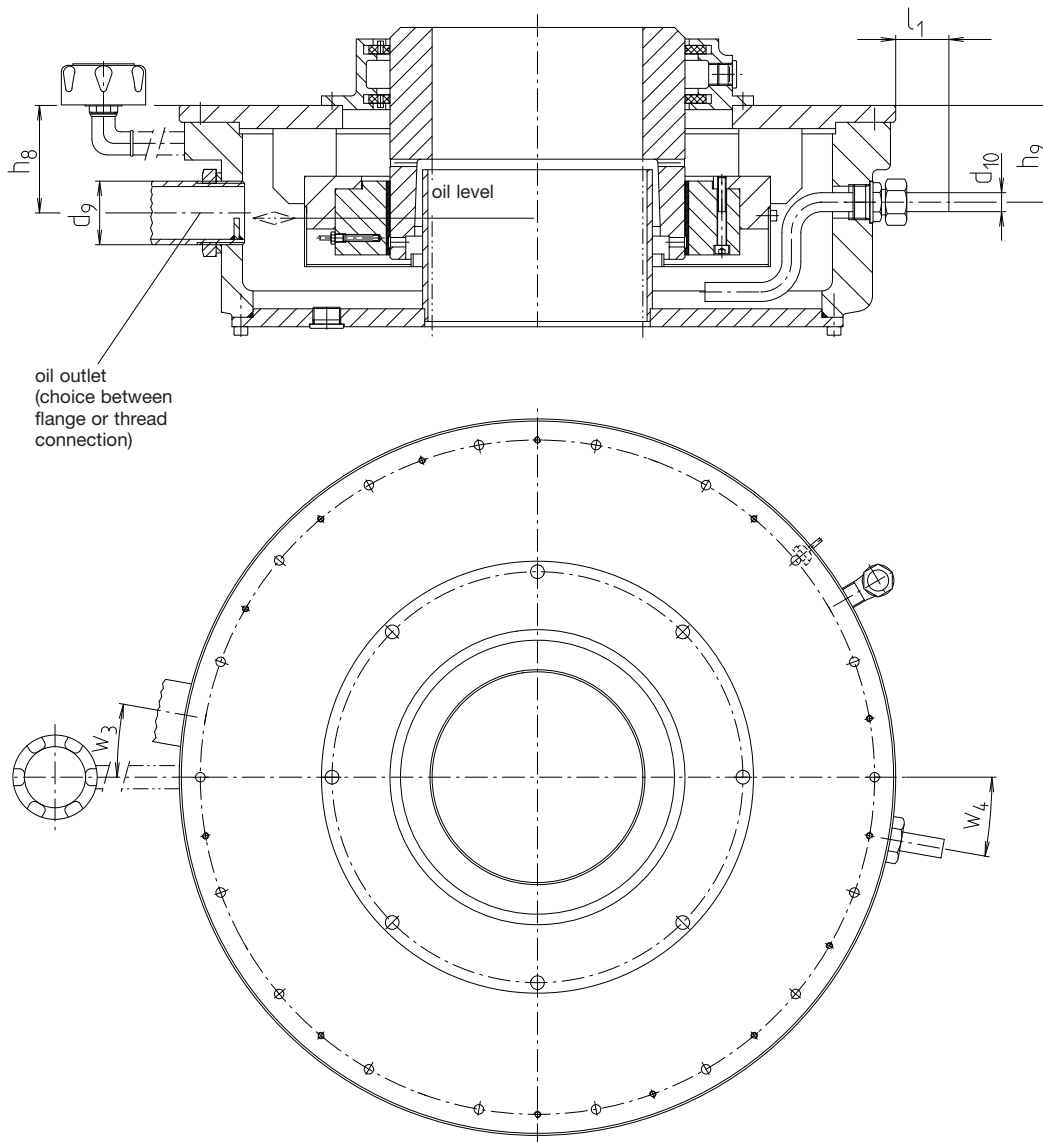

Dimensions in mm (for further dimensions please see page 6)

Size VGZ	d _g ²⁾	d ₁₀	h ₈	h ₉	l ₁	w ₃ [°]	w ₄ [°]	Weight [kg] ¹⁾	Oil quantity [l]
7-5	G 1	10	58	48	35	15	15	62	7
9-5	G 1 1/4	12	55	45	35	15	15	65	8
11-5	G 1 1/2	12	70	60	38	15	15	75	4
14-10	G 1 1/2	15	90	75	45	15	15	130	7
16-16	G 1 1/2	18	100	85	55	10	10	200	16
18-16	G 2	18	100	85	55	10	10	230	14

Size VGZ	d _g ²⁾	d ₁₀	h ₈	h ₉	l ₁	w ₃ [°]	w ₄ [°]	Weight [kg] ¹⁾	Oil quantity [l]
20-28	G 2	18	120	105	55	10	10	305	29
22-28	G 2 1/2	22	100	80	55	10	10	345	33
25-40	G 2 1/2	22	130	115	55	9	9	515	43
28-55	G 2 1/2	22	140	125	50	9	9	725	66
31-55	G 2 1/2	22	120	105	50	9	9	895	69
40-78	G 3	25	120	105	60	7,5	7,5	1185	97

1) without lubricant filling

2) flange connection upon request



Further Types Special Design Bearings



Type VB

This bearing type can absorb thrust loads in both directions. The bearing shell can be made to accommodate a variable number of RS-thrust pads to carry the upward thrust load. Upon receipt of the proposed operational duty, we will determine the correct number of RS-thrust pads and the housing size.

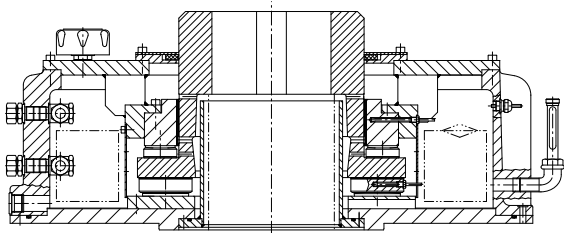

Bearing size	F_{AX} □ [kN]
7	—
9	35
11	47
14	90
16	111
18	157
20	173
22	204
25	220
28	348
31	442
40	560

VBWCU

Type V.F

Both the natural cooled bearing (N) and the water cooled bearing (W) can be additionally equipped with fan cooling. The fan cooling increases the rate of heat dissipation over the bearing housing.

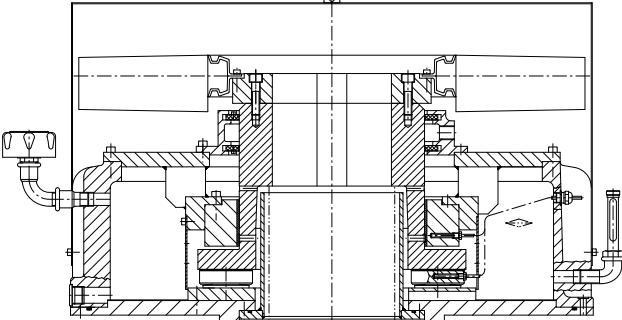

VTFCU

Type X (special) with hydrostatic jacking

To accommodate high axial loads (greater than the catalogue F_{as} values) from a standing start, the RD-thrust pads can be designed to inject high pressure oil from a hydrostatic jacking system.

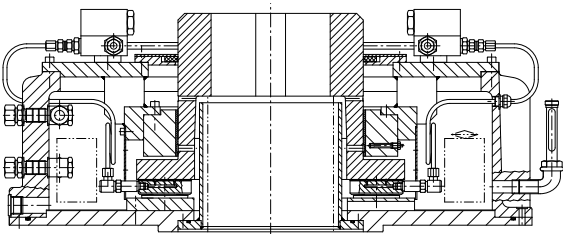

VXWCU

Type X (special) with enlarged axial part (F_{AB} ↓)

The admissible axial load can be increased by using bigger RD-thrust pads. In such cases there will be a reduction of the maximum diameter of shaft permitted in way of the stand pipe.

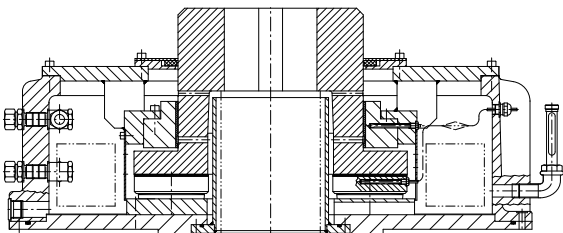

VXWCU





Sealing Systems for V-Bearings

The shaft seals are meant to:

- prevent oil getting out of the bearing,
- prevent penetration of water or foreign particles such as sand dust, into the bearing.

Based on the modular unit system and depending on the application cases the bearings are equipped with the corresponding sealing systems.

The shaft seals must meet certain requirements, such as for instance, to prevent the penetration of water or foreign particles.

Upon delivery of the operational requirements RENK can determine the necessary sealing system. The customer's specifications on protection grade according to DIN 40050 or IEC-529 are extremely useful in selecting the correct sealing arrangement.

Stand pipe with / without pipe seal

The stand pipe is attached to the bottom side of bearing and keeps the oil inside the tank.

With speeds over 13,5 m/s the journal bearing is provided with a stand pipe seal. The stand pipe seal controls the formation of foam within the oil bath of the bearing.

The stand pipe meets with the following protection requirements:
Stand pipe with / without seal IP 23.

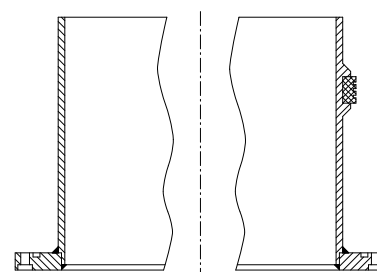

Single gap seal

The single gap seal is mounted on the top and bottom side of the bearing. Fixed to the top of the bearing the gap seal functions as a standard seal.

The single gap seal can be fixed to the bottom side of the bearing in addition to the stand pipe (with / without stand pipe seal).

The single gap seal corresponds to the following protection grades:
single gap seal on the top IP 42
single gap seal on the bottom in addition to the stand pipe with /without stand pipe seal IP 43.



Double seal (DUO-seal) with connections for air seal / pressure compensation

The use of the DUO-seal increases the protection grade. Before determining the seal type it is necessary to clarify which side (bottom or top) of the bearing must be protected.

The DUO-seal corresponds to the following protection grades:
Duo seal on the top IP 44
DUO seal on the bottom additionally to the stand pipe with / without stand pipe seal IP 44.

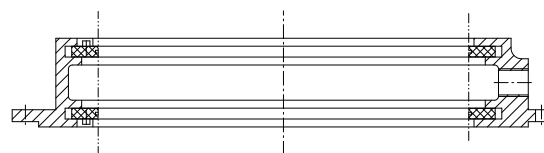

Labyrinth seal with single gap seal and grease packing

This type of seal is mainly used to protect the top of the bearing. Due to the additional grease packing this seal can be used in almost all application fields.

The labyrinth seal with single gap seal and grease packing corresponds to the protection grade IP 56.

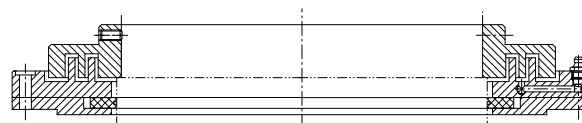



Product Range

Journal and thrust slide bearings and inserts

Type E	for electrical machines, fans, compressors, turbines	Catalogue-No. RH-1009
Type I	for tube mills and crushers	Catalogue-No. RH-1120
Type M	for general mechanical engineering applications	Catalogue-No. RH-1065
Type SN	aftermost and intermediate bearings for marine applications	Catalogue-No. RH-1202
Type SC	journal bearings for use with Diesel generators and rolling mills	Catalogue-No. RH-1149
Type HG	for Hydro turbine alternators and electric drive motors	Catalogue-No. RH-1189
Type WG	in welded design for steel mill drive applications	Catalogue-No. RH-1155
Type DN	thrust bearings for marine applications	Catalogue-No. RH-1073
Type VT and VG	complete vertical thrust and guide bearings	Catalogue-No. RH-1153
Type EV	vertical bearing inserts for electrical machines, pumps and fans	Catalogue-No. RH-1021
Type G	plain bearing shells for gears, pumps etc.	Catalogue-No. RH-1102
Type SH	trunnion bearings for tube mills	Catalogue-No. RH-1147
ROTRIX	trunnion bearings	Catalogue-No. RH-1089
RD-thrust bearings	standard thrust internals (cup spring supported)	Catalogue-No. RH-1025
RS-thrust pads	standard range thrust pads (ball pivoted)	Catalogue-No. RH-1198
Special bearings	RENK can design and manufacture special bearings for a wide range of industrial applications (e.g. type WG bearings with fabricated housing for rolling mill drives). RENK also manufacture bearings, shells etc. to customers designs and drawings	

Couplings

ELCO	flexible compression sleeve coupling	Catalogue-No. RH-1008
ELBI	flexible coupling for general mechanical engineering	Catalogue-No. RH- 076
AERO	pneumatically shifting friction coupling	Catalogue-No. RH-1118
	centrifugal clutch	Catalogue-No. RH-1014
	overrunning clutch	Catalogue-No. RH-1013
	diaphragm clutch	Catalogue-No. RH-1063
	special couplings and clutches	

EDP-computer calculations for slide bearings and ELCO-couplings.

Sales Organisation



Domestic + Export

Weltausstellungsallee 21
30539 Hannover
Telephone: (5 11) 86 01-210/ -274
Telefax: (5 11) 86 01-288

Sales Agencies

Australia
Austria
Belgium
Brazil
Canada
Czech Republic
Croatia
Finland
France

G.B. and Ireland
Hungary
India
Italy
Japan
Liechtenstein
Luxembourg
Mexico
Netherlands

Norway
PR China
Slovak Republic
Slovenia Republic
South Africa
South Korea
Spain
Switzerland
USA

Headquarters and Manufacturing Plant



RENK AKTIENGESELLSCHAFT
Werk Hannover
Weltausstellungsallee 21
D-30539 Hannover
Phone: +49 (5 11) 86 01-0
Fax: +49 (5 11) 86 01-288
Email: gleitlager.hannover@renk-ag.com
Internet: www.renk-ag.com

Assembly and Distribution Centers with Sales and Engineering Support

RENK Corporation
304, Tucapau Road
29334 Duncan S.C.
USA
Telefon: (1-8 64) 4 33 00 69
Telefax: (1-8 64) 4 33 06 36

OMEGA RENK BEARINGS PVT. LTD.
Anand Nagar, Raisen Road
Bhopal - 462 021
India
Telefon: (91 -7 55) 5 28 45 61
Telefax: (91 -7 55) 2 75 16 26

MAN B&W (Japan) Ltd.
RH Division;
Fuji Building (Room 121)
3-2-3 Marunouchi
Chiyoda-ku, Tokyo 100-0005
Japan
Telefon: (81-3) 3215 1310
Telefax: (81-3) 3284 0867

We reserve the right to changes made in the interests of technical improvement.